

## ASSEMBLY INSTRUCTIONS

Occasionally our products contain components that are pre-lubricated at the factory. We recommend that you protect flooring, or anything else the parts may contact, with newspaper or cloth.

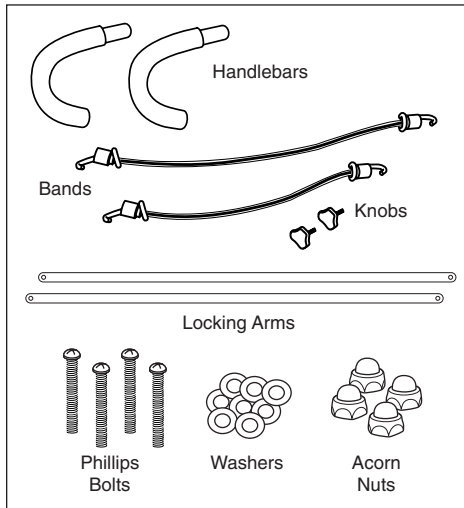
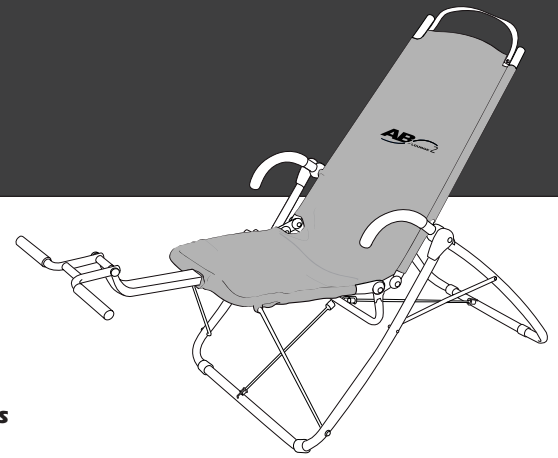

### Parts Box/Fasteners Includes

- Handlebars
- 2 Bands
- 2 Knobs for Handlebars
- 2 Locking Arms
- 4 Phillips Bolts for Locking Arms
- 8 Washers
- 4 Acorn Nuts

### Tools Included:

- Phillips Screwdriver
- 1 mm Wrench

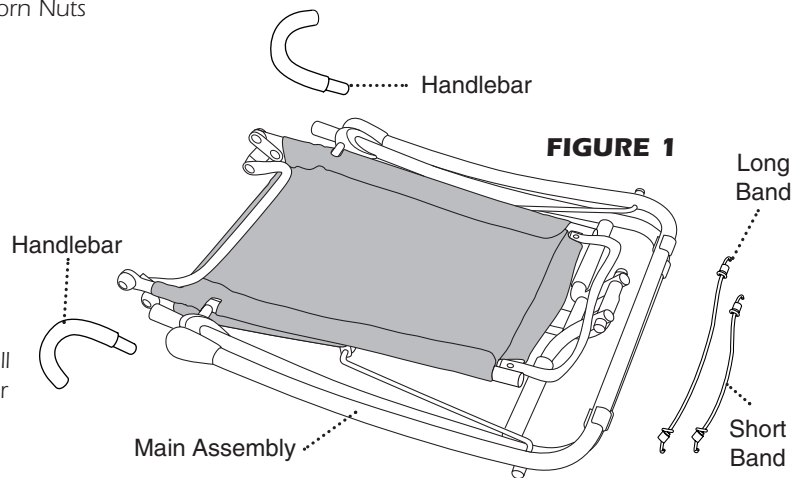

**Step 1.** Remove the Main Assembly and all parts from packing and place them on floor as shown in Figure 1.

**Step 2.** Lift and place the unit on its right side with the left side facing up as shown in Figure 2. Open the unit by grasping the bottom of the Front and Rear Frames and push them apart.

**Note: Bolts must be inserted from outside-to-inside the frame when installing each locking arm.**

- a.** Position (1) Locking Arm under the Left Front Frame and align bolt holes. Insert (1) Phillips Bolt and (1) Washer from the outside of the frame as shown in Figure 2a. Secure with (1) Washer and (1) Acorn Nut installed from under the Left Front Frame. Tighten bolt.
- b.** Rotate loose end of Locking Arm to the top side of the Left Rear Frame and align bolt holes, see Figure 2b. **Note: Locking Arm will be on the inside of the Left Front Frame and on the outside of the Left Rear Frame.** Secure with (1) Washer and (1) Acorn Nut installed under the Left Rear Frame. Tighten bolt. **Keep unit in this position to continue assembly.**
- c.** Position (1) Locking Arm on top of Right Front Frame and align bolt holes. Lift unit slightly and insert (1) Phillips Bolt and (1) Washer from bottom of Right Front Frame as shown in Figure 2c. Secure with (1) Washer and (1) Acorn Nut installed from top of Right Front Frame. Hand tighten bolt.
- d.** Rotate loose end of Locking Arm to the underside of the Right Rear Frame and align bolt holes, see Figure 2d. **Note: Locking Arm will be on the inside of the Right Front Frame and on the outside of the Right Rear Frame.** Secure with (1) Washer and (1) Acorn Nut installed from the top of Right Rear Frame. Hand tighten bolt.

Tighten bolts. If you have difficulty tightening bolts while the unit is lying down, stand unit upright.

CONTINUED ON BACK

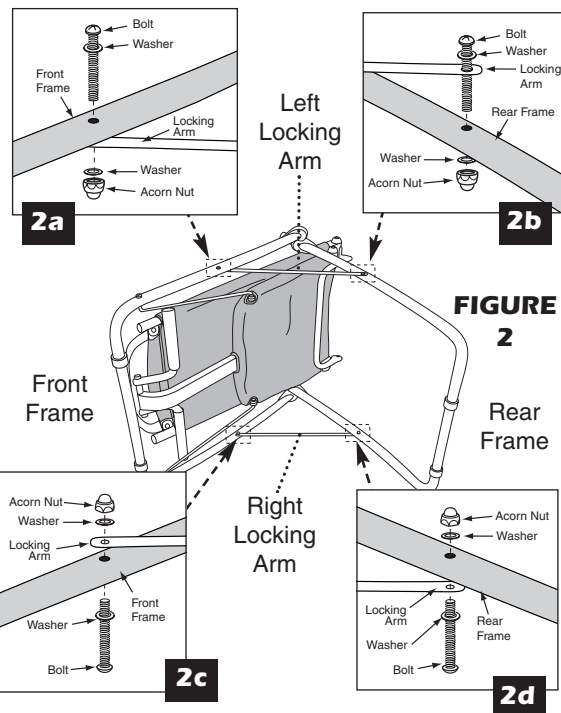

**Step 3.** Lay the unit on either side. While standing between the two frames, push the Foot Rest out away from you as shown in 3A.

The Seat and Back will start to separate (open up). Continue pushing outward until the Seat and Back are approximately 2 feet apart as shown in 3B.

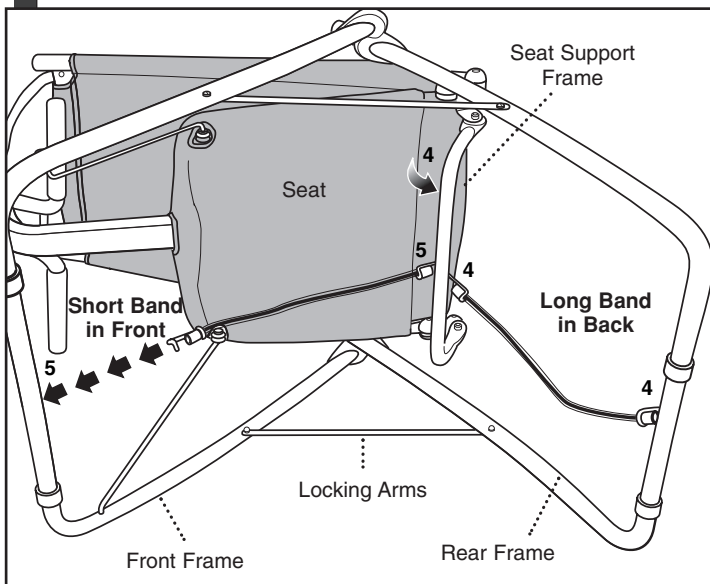
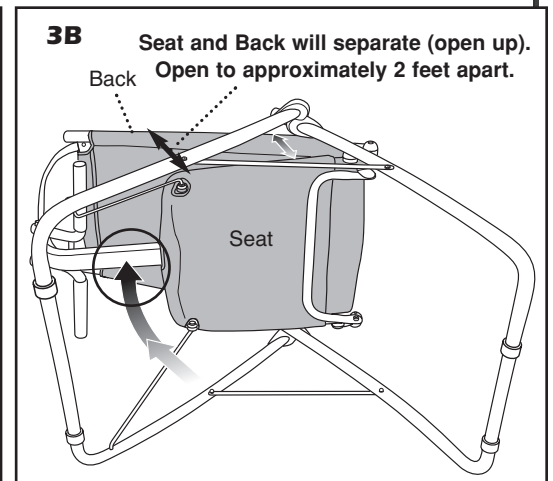
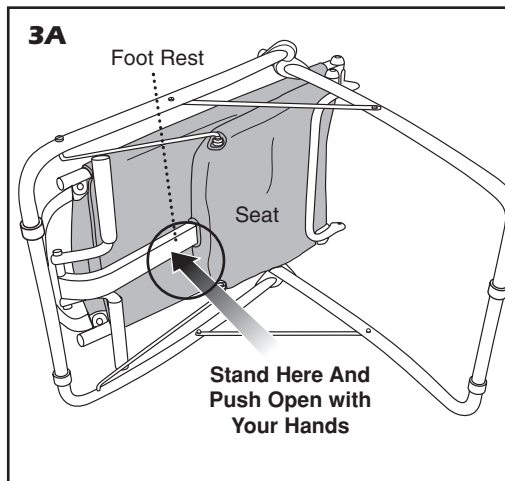

**Step 4.** Pull the Seat Support Frame toward you and locate the two holes on the top of this bar. Hook the Long Band over and attach to the lower hole of the Seat Support Frame. Hook the other end of the Long Band into the hole on the Rear Frame. Make sure hooks are inserted completely as shown here.

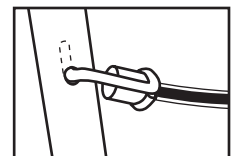

**NOTE: The chair will pivot easily at this point. Make sure you hold the Frame firmly in place as you attach the bands.**

**Step 5.** Place the Short Band Hook into the upper hole on the Seat Support Frame and hook the other end into the hole on the Front Frame.



**Step 6.** Slide the Handlebars into the holes at the top of the Main Assembly with the curves facing down. Align mounting hole and secure each handlebar in place using one of the knobs provided.

**Check all bolts and nuts to be sure they are tight before using your unit.**